

**LAB MANUAL
FOR
ELECTRICAL MACHINE LAB-I
SEMESTER-4TH
DEPARTMENT OF ELECTRICAL ENGINEERING**



**GOVT. POLYTECHNIC
SONEPUR**

GENERAL LABORATORY INSTRUCTIONS

- You should be punctual for your laboratory session and should not leave the lab without the permission of the teacher.
- Each student is expected to have his/her own lab book where they will take notes on the experiments as they are completed.
- The lab books will be checked at the end of each lab session. Lab notes are a primary source from which you will write your lab reports.
- You and your batch mates will work closely on the experiments together. One partner doing all the work will not be tolerated. All the Batch mates should be able to explain the purpose of the experiment and the underlying concepts.
- Please report immediately to the member of staff or lab assistant present in the laboratory; if any equipment is faulty.

ORGANIZATION OF THE LABORATORY

- It is important that the experiments are done according to the timetable and completed within the scheduled time.
- You should complete the pre lab work in advance and utilize the Laboratory time for verification only.
- The aim of these exercises is to develop your ability to understand, analyze and test them in the laboratory.
- A member of staff and a Lab assistant will be available during Scheduled laboratory sessions to provide assistance.
- Always attempt experiments; first without seeking help.
- When you get into difficulty; ask for assistance.

ASSESSMENT

- The laboratory work of a student will be evaluated continuously during the semester for 25 marks. Of the 25 marks, 15 marks will be awarded for day-to-day work.
- For each experiment marks are awarded under three heads:
 - _ Pre lab preparation – 5 marks
 - _ Practical work – 5marks, and
 - _ Record of the Experiment – 5marks
- Internal lab test(s) conducted during the semester carries 10 marks.
- End semester lab examination, conducted as per the JNTU regulations, carries 50 marks.
- At the end of each laboratory session you must obtain the signature of the teacher along with the marks for the session out of 10 on the lab notebook.

LAB REPORTS

- Note that, although students are encouraged to collaborate during lab, each must individually prepare a report and submit.
- They must be organized, neat and legible.
- Your report should be complete, thorough, understandable and literate.

- You should include a well-drawn and labeled engineering schematic for each circuit Investigated.
- Your reports should follow the prescribed format, to give your report structure and to make sure that you address all of the important points.
- Graphics requiring- drawn straight lines should be done with a straight edge. Well drawn freehand sketches are permissible for schematics.
- Space must be provided in the flow of your discussion for any tables or figures. Do not collect figures and drawings in a single appendix at the end of the report.
- Reports should be submitted within one week after completing a scheduled lab session.

PRESENTATION

- Experimental facts should always be given in the past tense.
- Discussions or remarks about the presentation of data should mainly be in the present tense.
- Discussion of results can be in both the present and past tenses, shifting back and forth from experimental facts to the presentation.
- Any specific conclusions or deductions should be expressed in the past tense.

REPORT FORMAT

Lab write ups should consist of the following sections:

- **Aim:** A concise statement describing the experiment and the results. This is usually not more than 3 sentences. Since the abstract is a summary of what you have done, it's a good idea to write this last.
- **Apparatus:** Describe what equipment and components you used to conduct the experiment.
- **Theory:** Several paragraphs that explain the motivation of the experiment. Usually in this statement you state what you intent to accomplish as well as the expected results of the experiment.
- **Procedure:** Describe how you conducted the experiment
- **Results and Analysis:** This is the main body of the report. Graphs, tables, schematics, diagrams should all be included and explained. Results of any calculations should be explained and shown. State the results of the experiment. Include any problems encountered.
- **Conclusion:** Explain how the experiment went, and whether you were able to achieve the expected results stated in the introduction.

GENERAL LABORATORY RULES AND PRECAUTIONS FOR ELECTRICAL SAFETY

The following general rules and precautions are to be observed at all times in the laboratory.

- 1. There must be at least two (2) people in the laboratory while working on live circuits.**
- 2. Shoes must be worn at all times.**
- 3. Remove all loose conductive jewellery and trinkets, including rings, which may come in contact with exposed circuits. (Do not wear long loose ties, scarves, or other loose clothing around machines.)**
- 4. When making measurements, form the habit of using only one hand at a time. No part of a live circuit should be touched by the bare hand.**
- 5. Never handle electrical equipment when hands, feet, or body are wet or perspiring or when standing on a wet floor.**
- 6. Keep the body, or any part of it, out of the circuit. Where interconnecting wires and cables are involved, they should be arranged so people will not trip over them.**
- 7. Keep the work area and workbench clear of items not used in the experiment.**
- 8. Always check to see that the power switch is OFF before plugging into the outlet. Also, turn instrument or equipment OFF before unplugging from the outlet.**
- 9. When unplugging a power cord, pull on the plug, not on the cable.**
- 10. When disassembling a circuit, first remove the source of power.**
- 11. Report any damages to equipment, hazards, and potential hazards to the laboratory instructor.**
- 12. Tie long hair to the back of the head.**

ELECTRIC SHOCK & it's MANAGEMENT

विद्युताघात एवं उसके प्रबंध नियम



Upon contact with live high tension wire.
उच्च विभववी विद्युत तार के सम्पर्क में आने पर।



Electric Shock upon contact with exposed live wire
निम्न विभववी विद्युत वाली खुली तार के सम्पर्क में आने पर।



EFFECTS प्रभाव

1. Fatal paralysis of heart.
घातक हृदय पक्षाघात।
2. Stoppage of breathing.
फेफड़ों का पक्षाघात, जिससे श्वास रुक जाता है।
3. Burns, deep or superficial or both.
जलने के घाव: त्वचा पर अथवा/और शरीर के अन्दर।

Electric Shock due to faulty electrical connections and carelessness.
दोष विद्युत संबन्धन व लापरवाही से विद्युताघात।

MANAGEMENT प्रबंध नियम

Switch off the power and remove the plug, if possible.
यदि सम्भव हो तो बिजली को सप्लाय काट दें या प्लग को बाहर निकाल लें।



2. Break electrical contact without directly touching the casualty.
अत्याहत या तार को बिना छूए, उनके बीच बिजली का सम्पर्क काट दें।

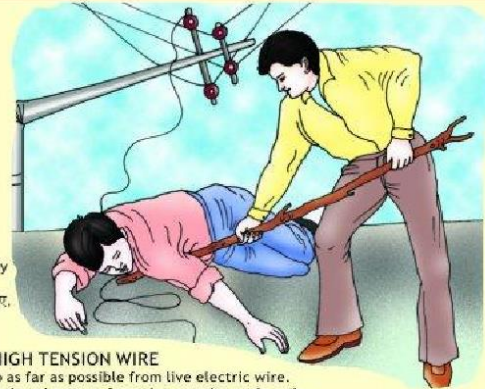

2. HIGH TENSION WIRE
Keep as far as possible from live electric wire.
Push the wire away from the casualty or drag the casualty away from the wire. Use only dry and non conducting material like rope, branch of a tree, dry cloth, etc.

2. उच्च विभववी विद्युत तार
जहाँ तक सम्भव हो विद्युत तार से दूर रहें।
किसी सूखे और अचालक पदार्थ जैसे रस्सी, कपड़े, या लकड़ी आदि के प्रयोग से घायल या तार को एक दूसरे से दूर करें।

1. EXPOSED LIVE WIRE

Stand on dry insulated material like wood, folded newspaper, rubber mat, etc.

1. निम्न विभववी विद्युत वाली खुली तार

लकड़ी को चौकी पर, समाचार पत्र के बंडल पर या रबड़ के पायदान, आदि पर खड़े हो जायें।

4.

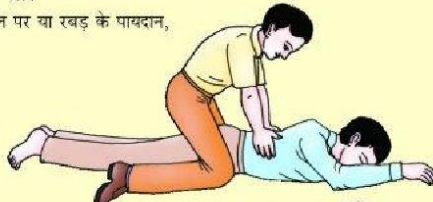

Apply expiration pressure.
श्वास बाहर निकालने के लिए छाती पर दबाव।

3.

3. Give artificial respiration & external cardiac massage.
कृत्रिम श्वास दें और बाह्य हृदय मर्दन करें।



Release pressure for inspiration.
श्वास अन्दर लाने के लिए दबाव हटावें।



Do not give casualty anything to drink. Rinse the burnt area with cold water and apply bandage.
घायल को पीने के लिए कुछ न दें। जले के घाव पर ठंडा पानी डालें और उस पर पट्टी करें।



Expiration by chest compression.
श्वास बाहर निकालने के लिए छाती पर दबाव।



Inspiration by chest expansion.
छाती को ढोला छोड़कर श्वास अन्दर आने दें।

5.

HOSPITAL



Call the doctor or take the casualty to a hospital.
डॉक्टर को बुलाएँ या घायल को अस्पताल ले जायें।

PUBLISHER: VIDYA CHITRA PRAKASHAN, F-1 ANSARI ROAD, BARIBAGAN, NEW DELHI-110 002, Ph: 11-23271400 | 9810815444, Email: vcpdelhi@gmail.com Website: www.vcp.in

PRECAUTIONS पूर्ववधान

LOW VOLTAGE

1. Seek professional help.
2. Stand on a dry insulated material like wooden planks, folded newspaper, rubber mat, etc. and use insulated tools only.
3. Use dry rubber gloves, if available.

HIGH VOLTAGE

1. Do not attempt yourself. Seek professional help.
2. Keep as far as possible from a snapped live H.T. wire.
3. Do not touch the casualty until the electrical contact is broken.

निम्न विभववी विद्युत तरंग

1. पेशेवर की सहायता लें।
2. लकड़ी को चौकी पर, अखबार के बंडल पर या रबड़ के पायदान, आदि पर खड़े हो कर ही काम करें। अचालक औजारों का ही प्रयोग करें।
3. यदि रबड़ के दस्ताने उपलब्ध हों तो उनका प्रयोग करें।

उच्च विभववी विद्युत तरंग

1. पेशेवर की सहायता लें।
2. जितना सम्भव हो विद्युत तार से दूर रहें।

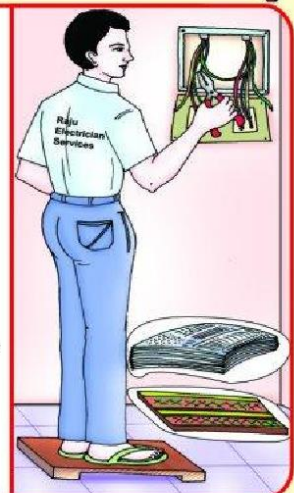

1. IDENTIFICATION OF DIFFERENT TERMINALS OF A DC MACHINE BY TEST LAMP METHOD AND MULTIMETER METHOD AND TO MEASURE INSULATION RESISTANCE BY MEGGER

AIM: IDENTIFICATION OF DIFFERENT TERMINALS OF A DC MACHINE BY TEST LAMP METHOD AND MULTIMETER METHOD AND TO MEASURE INSULATION RESISTANCE BY MEGGER.

APPARATUS REQUIRED

S.NO	Name of the tools/equipments	specification	Type	Quantity
01	Screwdriver	150mm	Insulated	1No
02	Insulated combination pliers	6"	Insulated	1No
03	D.E. spanner set	5mm to 18mm		1Set
04	Series/ shunt type ohmmeter	0-50 ohms	Digital	1No
05	DC compound machine	220V/ 3KW		1No
06	PVC Insulated copper cable	1.5 sq mm	Multi core	5 m
07	Test lamp	220 v, 100 W		1No
08	Megger	500 v, 20 mega ohm	Analog	1No

PROCEDURE

TASK 1: Read and interpret the name plate details of a DC machine

1. Read the name-plated details of the given DC compound machine and record them.

Name plate details

Manufacturer-

Type, model-

Type of current

Function. Generator/motor-

Serial number-

Type of connection sep./shunt/series/compound-

Rated voltage volts-

Rated power k.w.-

Rated exc.voltage volts-

Rating class. -

Insulation class -

Rated current amps-

Rated speed .r.p.m.-

Rated Exc.current amps-

Direction of rotation-

Protection class-

2. Remove the terminal cover

3. Identify DC machines terminals.

TASK 2: Measure shunt field resistance by an ohmmeter

1. Take a series type ohmmeter or multimeter; select a proper ohmic range and set its value to zero by shorting the prods.

Connect the meter leads to the shunt field terminals of the machine as per the FIG.

2 Read, and record the value of the shunt field resistance below. The value of the shunt field resistance is

_____ ohms.

3. Refix the terminal cover

4. Compare the readings obtained in Tasks 1 and 3. If there is any difference write the reasons in the space given below

Task 3: Measure armature resistance using an ohmmeter

Adjust ohms'Zero'and ohms'Infinity'oftheohmmeter

1 Connect the ohmmeter across the armature terminals and measure the resistance.

Note down the meter reading and record it below. Armature resistance value is_____ohms.

2 Replacetheterminalcoverandkeep alltools,equipment and meters at theirplaces.

3 Compare the readings of Task 1 & 2. If there is any difference, find the reasons for that and write your conclusions in the space b

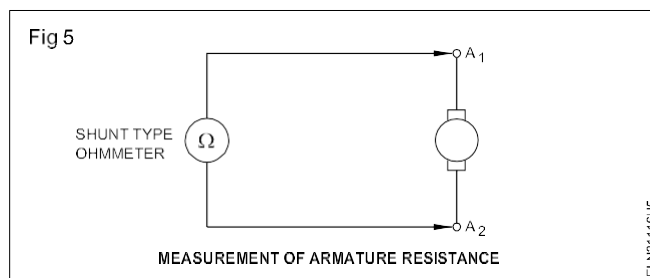

Test and identify the pairs of terminals of a DC compound machine

1. Prepare a test lamp for 240V 25W

2. Identify one of the cables as the phase cable and connect it to the test lamp through the switch and fuse

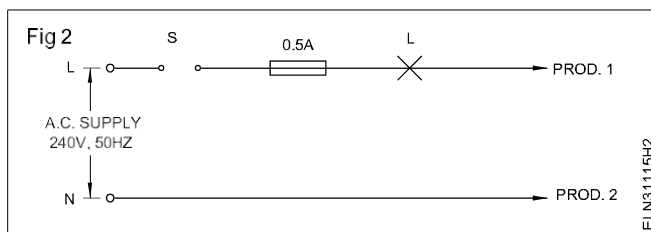

Connect Prod 1 of the test lamp to terminal 1 andtouch theother Prod 2 totherest of theterminals, oneby one

3. Check the condition of the lamp.

4. Connect Prod 1 of the test lamp to another terminal as shownin Fig 3 andrepeattheprocedureofsteps 2 and 3 to find the second pair of terminals and write the results in Table.

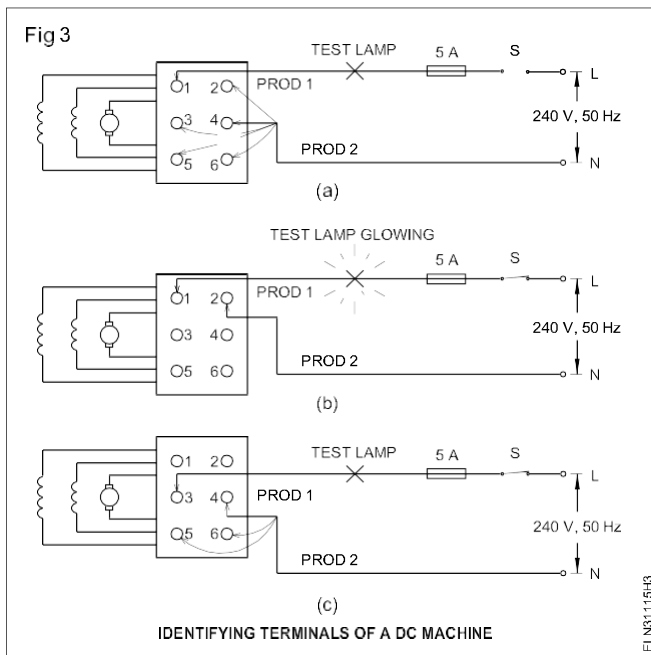

Sl no	Pairs of terminals	Condition of lamps	Identifi- cation
1	1 and 2		
2	1 and 2		
3	1 and 4		
4	1 and 5		
5	1 and 6		
6	3 and 4		
7	3 and 5		
8	3 and 6		
9	5 and 6		
10	Brush to -- 2		
11	Brush to -- 3		
12	Brush to -- 5		

Conclusion

Armature terminals _____ and _____. (Mark them as A_1 & A_2 .)

Shunt field terminals _____ and _____. (Mark them as E_1 & E_2 .)

Series field terminals _____ and _____. (Mark them as D_1 & D_2 .)

Task-4 Test a DC machine for insulation resistance between windings

- 1 Fill up the columns 1 to 4 in Table 1.
- 2 Connect the Megger between armature and shunt field terminals. (Fig 2)
- 3 Rotate the Megger at its rated speed, and note down the reading in Table 1.
- 4 Repeat step 3 for testing the insulation between the shunt field and series field after connecting the Megger terminals. (Fig 2)

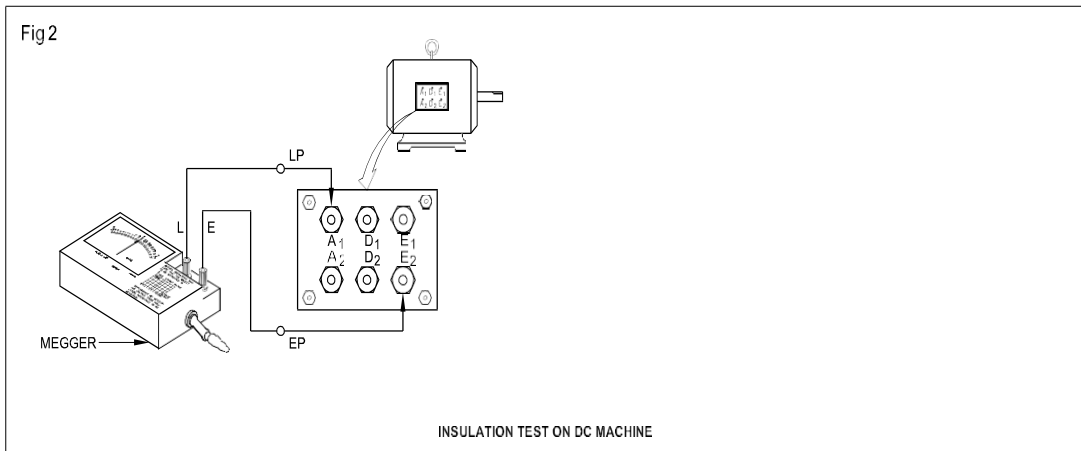

Insulation resistance test between windings of a DC machine

Date	Time	Weather condition	Duty cycle	Test between terminals	Insulation resistance in mega ohms	Remarks
1	2	3	4	5	6	7
				Armature and shunt field		
				Shunt and series field		
				Series field and armature		
				Armature and the body		
				Series field and the body		
				Shunt field and the body		

2. DIMENSIONAL AND MATERIAL STUDY OF VARIOUS PARTS OF DC MACHINE.

AIM: DIMENSIONAL AND MATERIAL STUDY OF VARIOUS PARTS OF DC MACHINE.

APPARATUS REQUIRED

S.NO	Name of the tools/equipments	specification	Type	Quantity
01	Pulley puller	6"		1No
02	Hammer	500 gms		1No
03	Cutting pliers	200mm		1No
04	Centre punch. Length	100mm		1No
05	Spanner set	5mm to 20mm		1Set
06	Screwdriver, heavy duty	12"	Insulated	1No
07	Mallet, hardwood.	60mm dia		1No
08	DC machine			1No

THEORY

Construction of DC Machine

The construction of DC machine can be done using some of the essential parts like Yoke, Pole core & pole shoes, Pole coil & field coil, Armature core, Armature winding conductor, commutator, brushes & bearings. Some of the parts of the DC machine is discussed below.

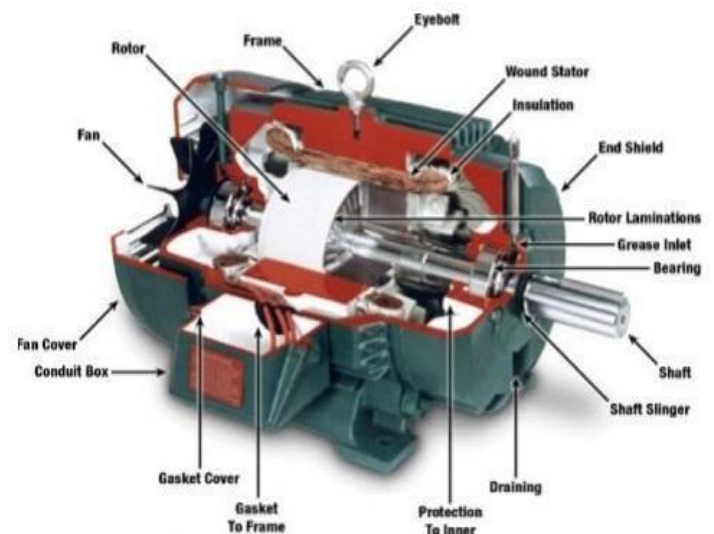
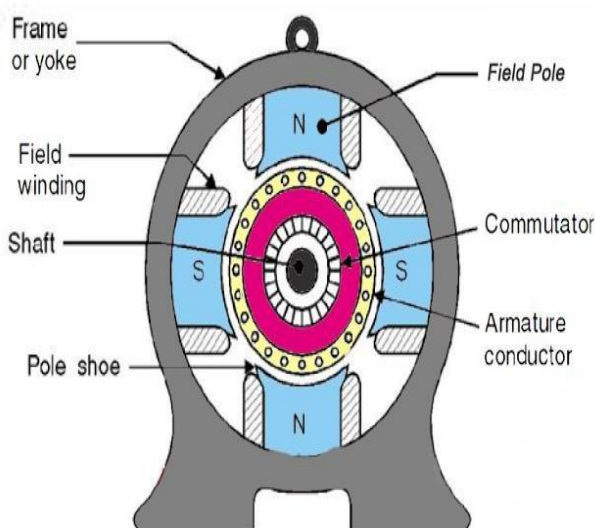

Yoke

Another name of a yoke is the frame. The main function of the yoke in the machine is to offer mechanical support intended for poles and protects the entire machine from the moisture, dust, etc. The materials used in the yoke are designed with cast iron, cast steel otherwise rolled steel.

Pole and Pole Core

The pole of the DC machine is an electromagnet and the field winding is winding among pole. Whenever field winding is energized then the pole gives magnetic flux. The materials used for this are cast steel, cast iron. It can be built with the annealed steel laminations for reducing the power drop because of the eddy currents.

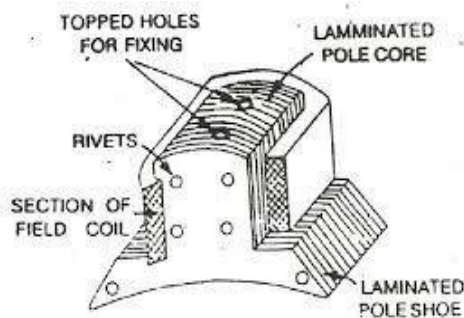

Pole Shoe

Pole shoe in DC machine is an extensive part as well as enlarge the region of the pole. Because of this region, flux can be spread out within the air-gap as well as extra flux can be passed through the air space toward armature. The materials used to build pole shoe is cast iron cast steel, and also used annealed steel lamination to reduce the loss of power because of eddy currents.

Field Windings

In this, the windings are wounded in the region of pole core & named as field coil. Whenever current is supplied through field winding then it electromagnet the poles which generate required flux. The material used for field windings is copper.



Armature Core

Armature core includes the huge number of slots within its edge. Armature conductor is located in these slots. It provides the low-reluctance path toward the flux generated with field winding. The materials used in this core are high permeability low-reluctance materials like iron cast steel. The lamination is used to decrease the loss because of the eddy current.



Armature Winding

The armature winding can be formed by interconnecting the armature conductor. Whenever an armature winding is turned with the help of prime mover then the voltage, as well as magnetic flux, gets induced within it. This winding is allied to an exterior circuit. The materials used for this winding are conducting material like copper.



shutterstock.com • 148663856

Commutator

The main function of the commutator in the DC machine is to collect the current from the armature conductor as well as supplies the current to the load using brushes. And also provides uni-directional torque for DC-motor. The commutator can be built with a huge number of segments in the edge form of hard drawn copper. The Segments in the commutator are protected from thin mica layer.



Brushes

Brushes in the DC machine gather the current from commutator and supplies it to exterior load. Brushes wear with time to inspect frequently. The materials used in brushes are graphite otherwise carbon which is in rectangular form.

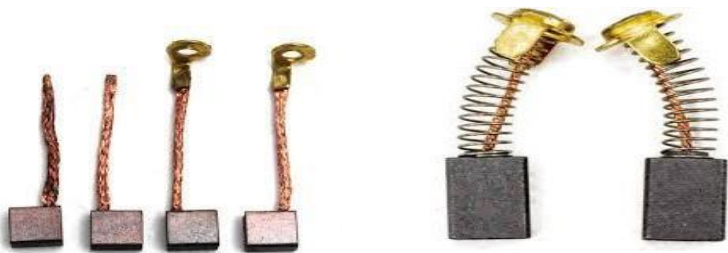

PROCEDURE

Dismantle, inspect and reassemble DC compound generator

- 1 Read the manufacturer's instruction booklet, and particularly take into account any special instructions regarding dismantling procedures.
- 2 Remove the fuse-carriers from the main switch, disconnect the DC machine from the supply and display the "Man-on-line board" on the main switch.
- 3 Remove the foundation bolts of the machine and shift the machine to the

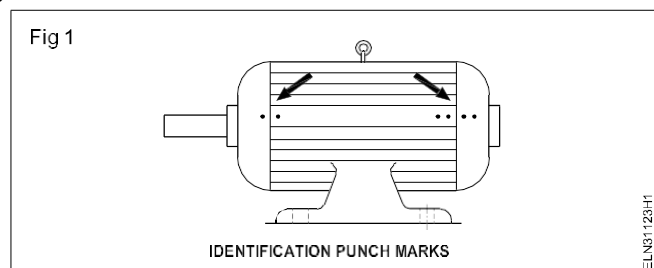

workbench.

- 4 Conduct a visual inspection.
- 5 Clean the outside surface of the motor. Remove all dirt and grease with a dry cloth soaked in petrol/kerosene.
- 6 Make punch marks on both the end plates and yoke. (Fig 1)
- 7 Mark the rocker arm position with respect to the end plate.
- 8 Remove the brushes from the brush-holder. (Fig 2)
- 9 Check pulley tight and adjust.
- 10 Remove the grease cup stud and open the grease cup
- 11 Loosen the studs of both the end plates and then remove the end plate of the shaft side.
- 12 Remove the armature from the body of the machine
- 13 Remove the bearings using a bearing puller
- 14 Reassemble the yoke, armature and end plates
- 15 Check the freeness of the shaft by rotating the shaft by hand
- 16 Insert the brush in the holder, adjust the brush tension, and bed the brushes
- 17 Position the rocker-arm in the end plates as per original marking.
- 18 Re-install the machine in the foundation and tighten the foundation bolts and connect the generator.
- 19 Check whether the generator is operating smoothly without any vibration.

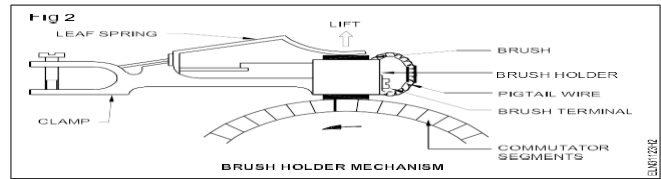

OBSERVATION

Table

Name plate details

Manufacturer-
 Type, model-
 Type of current
 Function. generator/motor-
 Serial number-
 Type of connection sep/shunt/series/compound-
 Rated voltage volts-
 Rated power k.w.-
 Rated exc.voltage volts-
 Rating class. -
 Insulation class -

Rated current amps-
 Rated speed .r.p.m.-
 Rated Exc.current amps-
 Direction of rotation-
 Protection class-

Stator Part

Sino	Name of the part	Measurement
01	Length of yoke	
02	Diameter of yoke	
03	No of poles	
04	Length of pole	
05	Width of pole	
06	No of inter poles	
07	No of carbon brushes	
08	No of bearing	

Rotor Part

Sino	Name of the part	Measurement
01	Length of shaft	
02	Length of armature	
03	Diameter of armature	
04	Length of commutator	
05	Diameter of commutator	
06	No of slots of armature	
07	Number of conductor in each slot	
08	Size of conductor	
09	No of commutator segment	

Reasoning questions:

- 1) What is the function of the commutator?
- 2) What is the function of brush?
- 3) What is slot?
- 4) What is the function of pole shoes?
- 5) Which type of material is required for armature core.
- 6) Which type of materials used for the construction of brushes.

CIRCUIT DIAGRAM:

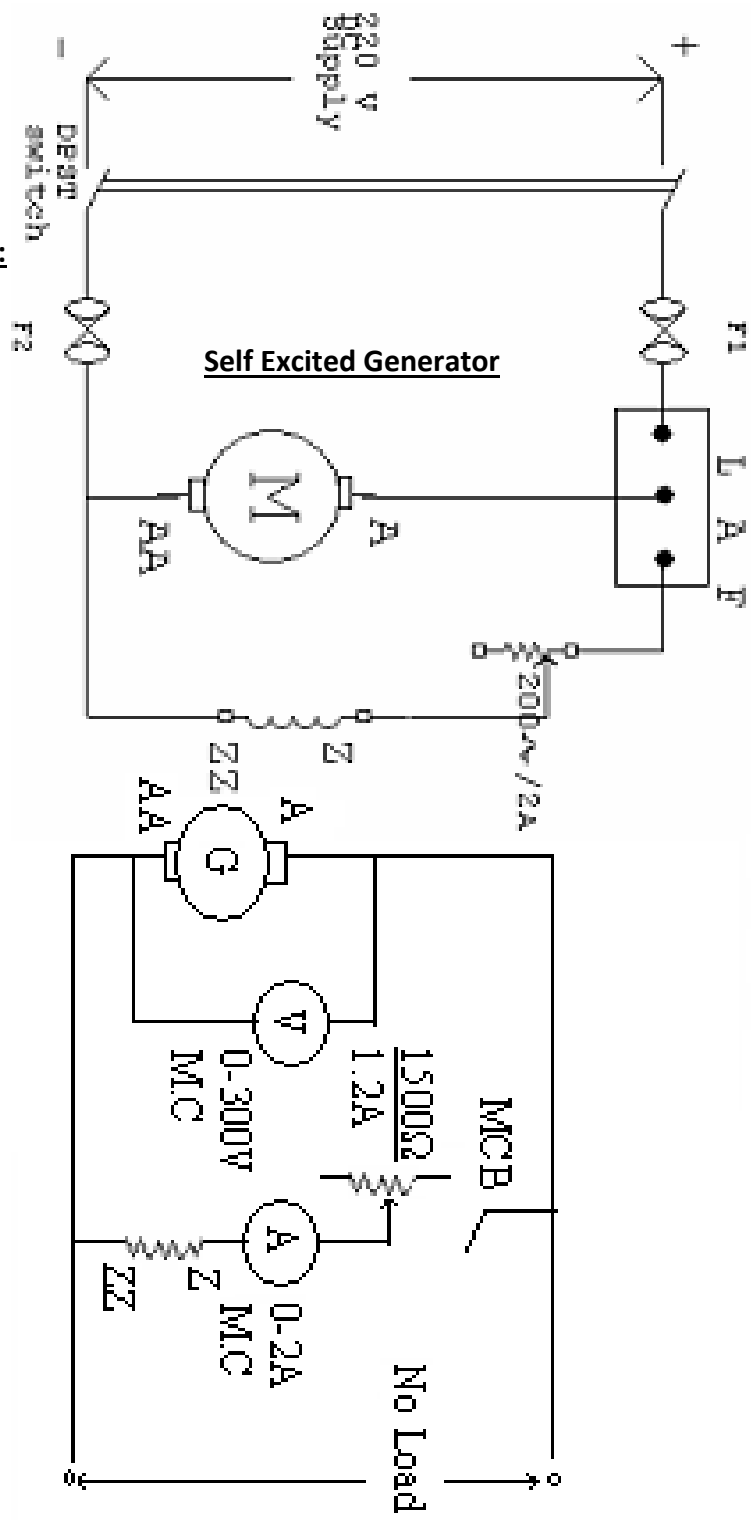

3. PLOT OCC OF A DC SHUNT GENERATOR AT CONSTANT SPEED AND DETERMINE CRITICAL RESISTANCE FROM THE GRAPH.

AIM: PLOT OCC OF A DC SHUNT GENERATOR AT CONSTANT SPEED AND DETERMINE CRITICAL RESISTANCE FROM THE GRAPH.

NAME PLATE DETAILS :

MOTOR

GENERATOR

1. Voltage :
2. Current :
3. Type equation here. H.P/ KW Rating :
4. Speed :

APPARATUS REQUIRED

S.NO	Name of the equipment	Range	Type	Quantity
1	DC Shunt Generator	230 v, 14 Amp, 3 kw, 1440 rpm	Shunt Motor	1No
2	Prime mover	230v,5 HP, 13.6 Amp, 1440 rpm	Shunt Motor	1No
3	Rheostats R1 R2	400 ohms,5A 400 ohms,5A	Variable type	1 No 1No
4	Voltmeter	0-300 v	Mc type	2No
5	Ammeter	0-5 A	Mc type	1No
6	Connecting Wire	1.5 sq. mm	Insulated	5m
7	Insulated combination plier	0-300 mm	Insulated	1 No
8	Electrician Knife	0-50 mm		1 No
9	Neon Tester	0-100 mm		1 No

THEORY:

The magnetization or Open Circuit Characteristic of a self-excited DC machine shows the relation between the No-load generated e.m.f (E_0) and Field current (I_f) at a given speed. It is the magnetization curve for the material of the electromagnetic pole core and its shape is practically same for all generators.

From the voltage equation of DC shunt generator,

$$E_g = \Phi ZNP / 60A$$

It can be seen that $E \propto \Phi$, when N is constant. Due to residual magnetism in the poles some e.m.f is generated even when $I_f = 0$. Hence the curve starts a little way up from the origin. excitation current, During this time the poles are unsaturated and curve is a straight line.

As the flux density increases, the saturation of poles sets in and the excitation current required to produce a particular change in voltage is more when compared to the initial parts of the curve. Hence, the curve

bends down.

The maximum voltage to which a shunt generator builds up depends on the total resistance in the field circuit and magnetization curve of the machine.

OBSERVATIONS:

Reading to draw OCC curve (If Vs Eo).

S.NO	Increasing mode		Decreasing mode	
	I _f	E ₀	I _f	E ₀

Critical field resistance R_c = _____ Ω

critical speed N_c = _____ rpm

B. Readings to calculate shunt field resistance (Rsh)

Average R_{sh} = _____ Ω

S.NO	I _{sh} in Amps	V _{sh} in Volts	R _{sh} =V _{sh} /I _{sh} in Ω

Model graph:

Slope of OB-Critical field resistance (R_c)

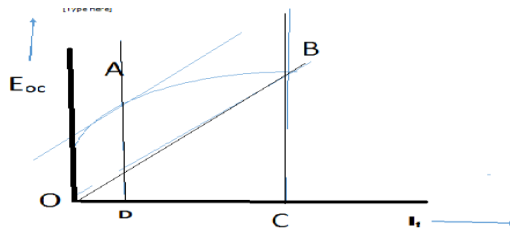

$$AD/BC = N_c/N$$

$$N_c = AD/BC \times N$$

The conditions for satisfactory voltage build up are:

- 1) Presence of Residual magnetism.
- 2) Correct direction of rotation.
- 3) Field Resistance lesser than critical resistance
- 4) Speed more than critical speed

Critical Field Resistance:

The maximum allowed value of the field resistance to a DC shunt generator, above which the voltage fails to build up, is called the Critical Field Resistance.

Critical speed:

It is the speed below which the machine cannot build up emf.

PROCEDURE:

1. Make the connections as per the circuit diagram.
2. Ensure minimum resistance in the field circuit.
3. Switch on the supply and run the generator without load.
4. Vary the field current in steps using the field rheostat.
5. Note down the values of Field current (I_f) and Generated e.m.f. (E) at each step.

PRECAUTIONS:

1. Avoid hanging wires and loose connections.
2. Make sure that the initial value of field Resistance is minimum.

Reasoning questions:

1. What is the purpose of starter for the motor ?
2. Why is the speed maintained constant during the experiment ?
3. Why is the motor field resistance kept to a minimum while starting the motor ?
4. What is residual magnetism ?
5. Define critical resistance ?
6. Define critical speed ?
7. Explain magnetization curve.
8. Explain hysteresis phenomena?

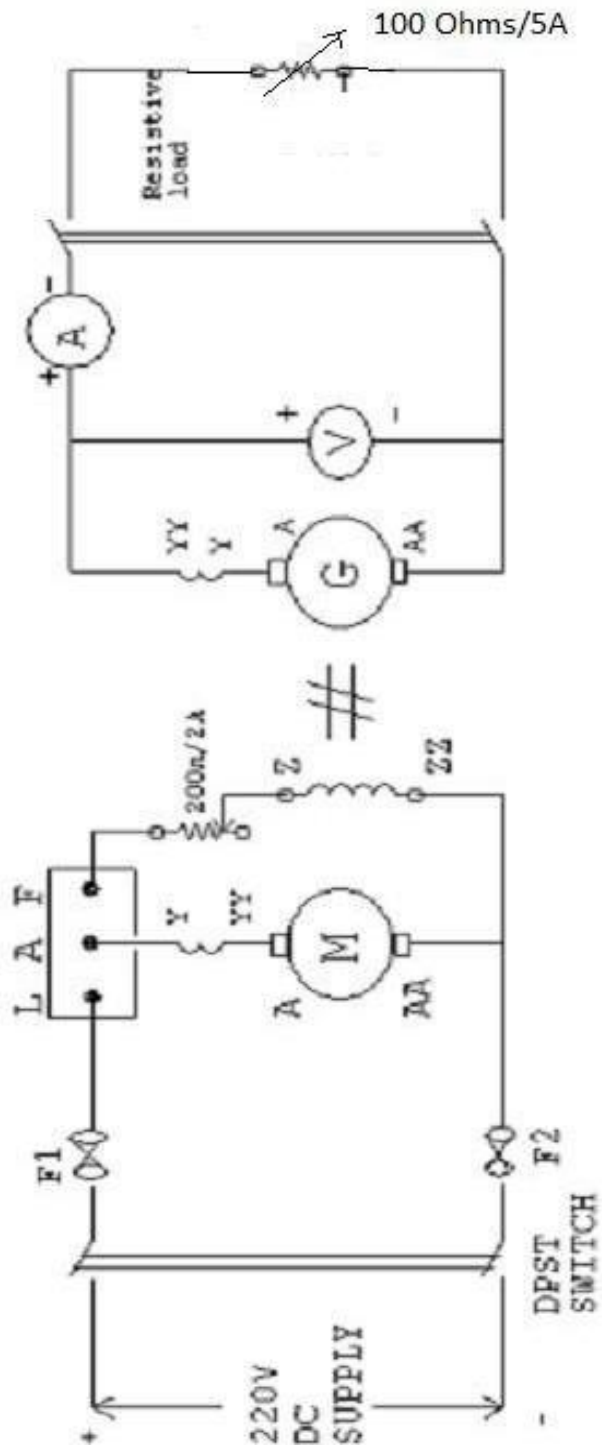

CIRCUIT DIAGRAM

4. PLOT EXTERNAL CHARACTERISTICS OF DC SHUNT GENERATOR AT CONSTAND SPEED

AIM: _PLOT EXTERNAL CHARACTERISTICS OF DC SHUNT GENERATOR AT CONSTAND SPEED

NAME PLATE DETAILS:

MOTOR

GENERATOR

1. Voltage :
2. Current :
3. H.P/ KW Ratings :
4. Speed :

APPARATUS REQUIRED:

S.NO	Name of the equipment	Range	Type	Quantity
1	DC Shunt Generator	230 v, 14 Amp, 3 kw, 1440 rpm	Shunt Motor	1No
2	Prime mover	230v,5 HP, 13.6 Amp, 1440 rpm	Shunt Motor	1No
3	Voltmeter	0-300 V	Mc type	2 Nos
4	Ammeter	(0-15 A)	Mc type	1 No
5	Ammeter	(0-15 A)	Mc type	1 No
6	Tachometer	(10000) R.P.M	Digital	1 No
7	Rheostats	400 Ohms,5Amp		2 Nos
8	Load Box	200 Watt each	Resistive	5 Nos
9	Connecting Wire	1.5 sq. mm	Multi core	5m
10	Insulated combination plier	0-300 mm	Insulated	1 No
11	Electrician Knife	0-50mm		1 No
12	Neon Tester	0-100 mm		1 No

THEORY:

One of the most important characteristics of any generator is it s behavior with regard to the terminal voltage when load increases. In shunt generator the voltage always falls as more current is delivered to the load. There are three reasons for this.

1. With increase in load current, the voltage drop in the armature ($I_a R_a$) increases, making a lower EMF available at the load terminals.
2. Also the armature reaction weakens the field, which reduces the EMF generated.
3. The drop of voltage due to (1) and (2) results in a decreased field current which further reduces the flux which in turn decreases the generated EMF. If the field is excited from an external source it will be independent of load current. As the flux is constant the internal characteristics must be a straight line. But due to armature reaction the internal characteristics will be a lit t le dropping.

PROCEDURE:

RESULTS & CONCLUSIONS:

Reasoning questions:

1. If the shunt generator fails to build-up the voltage what could be the reason for it?. Explain how this can be overcome.
2. Why are the characteristics of the shunt generator drooping?
3. Why DC generators are normally designed for maximum efficiency around the load?
4. Define commercial and electrical efficiencies for DC generators?
5. Which losses in a DC generator vary significantly with the load current?
6. Draw the internal and external characteristics for a DC shunt generator.

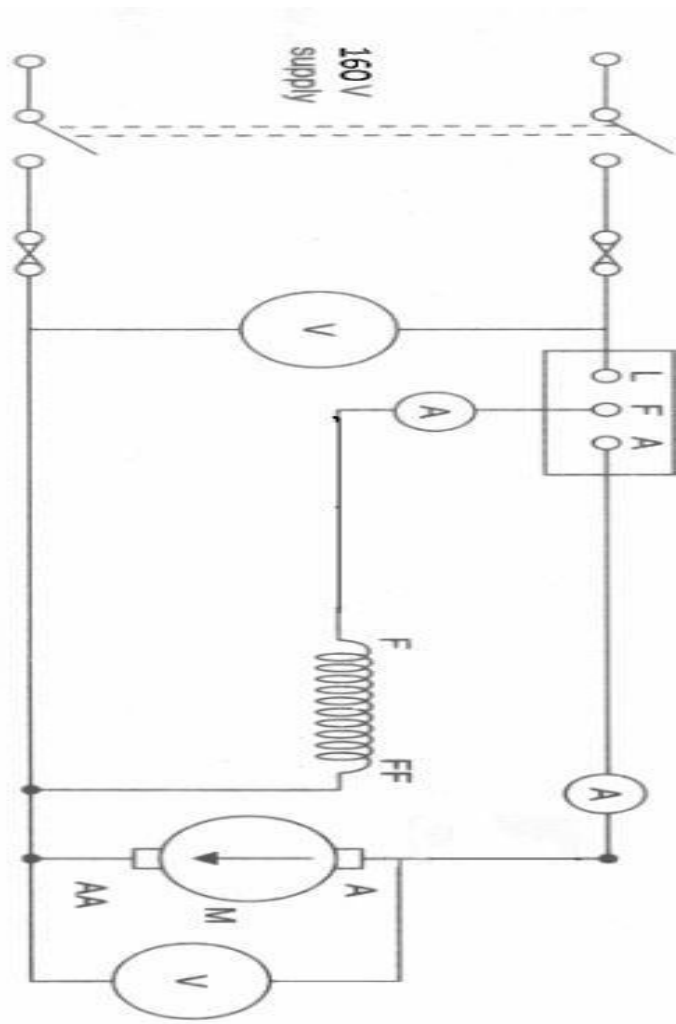

CIRCUIT DIAGRAM

5. STUDY OF THREE POINT STARTER,CONNECT AND RUN A D.C SHUNT MOTOR AND MESURE THE NO LOAD CURRENT

AIM: STUDY OF THREE POINT STARTER, CONNECT AND RUN A D.C SHUNT MOTOR AND MESURE THE NO LOAD CURRENT

APPARATUS REQUIRED:

S.NO	Name of the equipment	Range	Type	Quantity
1	DC Shunt Motor	220 V,2 HP,1450 rpm, 3.8 Amp	Shunt	1 No
2	3 Point Starter	230 V, 5HP		1 No
3	Series Testing Board	230 v,100 W	AC	1 No
4	Multimeter		Digital	1 No
5	Voltmeter	0-300 v	M.C. type	1 No
6	Ammeter	0-15 amp	M.C. type	1 No
7	Rheostats	400 Ohms,5amp		1 No
8	Tachometer	10000 rpm	Digital	1 No
9	Insulated combination plier	0-300 mm	Insulated	1 No
10	Electrician Knife	0-50mm		1 No
11	Neon Tester	0-100 mm		1 No
12	Connecting Wire	1.5 sq. mm		5 m

THEORY

A three-point starter is a device that *helps in starting and running the shunt wound motor or compound wound DC motor.*

Starters are used to protect DC motors from damage that can be caused by very high current and torque during startup. They do this by providing external resistance to the motor, which is connected in series to the motor's armature winding and restricts the current to an acceptable level.

NEED OF STARTER

To see why DC motors experience high startup current, we can examine the voltage equation of a DC motor:

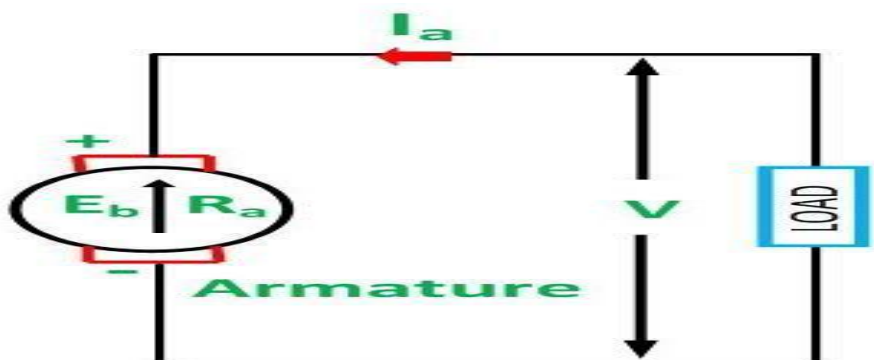

$$E = E_b + I_a \cdot R_a$$

Where:

E = supply voltage

E_b = back EMF

I_a = armature current

R_a = armature resistance

Back EMF is directly proportional to the motor's speed, so at startup, when motor speed is zero, back EMF is also zero. Therefore, removing the E_b term and rearranging the voltage equation, we can see that, at startup, armature current is inversely proportional to armature resistance.

$$I_a = \frac{E}{R_a}$$

For the best motor performance, armature resistance in DC motors is kept very low (typically less than 1 ohm). To see how significantly this affects the starting current, we can assume that armature resistance (R_a) is 0.4 ohm and supply voltage (E) is 220 V. This gives a starting current (I_a) of 550 amps, which can be more than ten times the rated current, and high enough to damage the internal motor circuit.

Not only can the high startup current result in potential motor circuit damage, it can also produce dangerously high torque, which can cause the rotor to literally break apart. From the DC motor torque equation, we can see that torque is directly proportional to current:

$$T = k_a \cdot \phi \cdot I_a$$

Where:

T = torque

k_a = torque constant

ϕ = motor flux

To combat these problems, a motor starter adds external resistance (R_s) to the armature winding, which reduces the armature current:

$$I_a = \frac{E}{R_a + R_s}$$

But this resistance doesn't need to be present through the motor's full operating speed range. As motor speed increases, back EMF develops, which counters the supply voltage and also has the effect of reducing armature current:

$$I_a = \frac{E - E_b}{R_a + R_s}$$

As the back EMF reaches its maximum, the starter progressively decreases the external resistance, R_s , to zero

Consist of a variable resistance. having a number of contact points Off.1.2.3.4.5 called as studs.

There are three terminals in 3-point starter:

- 'L' Line terminal: (Connected to positive supply)
- 'A' Armature terminal. (Connected to armature winding)
- 'F' Field terminal (Connected to field winding)

Point L is further connected to electromagnet called OLR (overload release)

The second point of OLR is connected to the starter handle.

The handle is free to move on other side towards RUN against the force of spring A soft iron piece is attached to handle.

- A parallel path is derived from stud 1 to No Volt coil (NVC) and other end of NVC is connected to 'F' terminal.
- The Overload release (OLR) and No volt coil (NVC) are two protective devices.

Operation of three-point starter

The handle is in OFF position:

When power is switched on to the motor. The handle is slowly moved to stud '1' against the spring force, the following will happen:

Construction of three-point starter

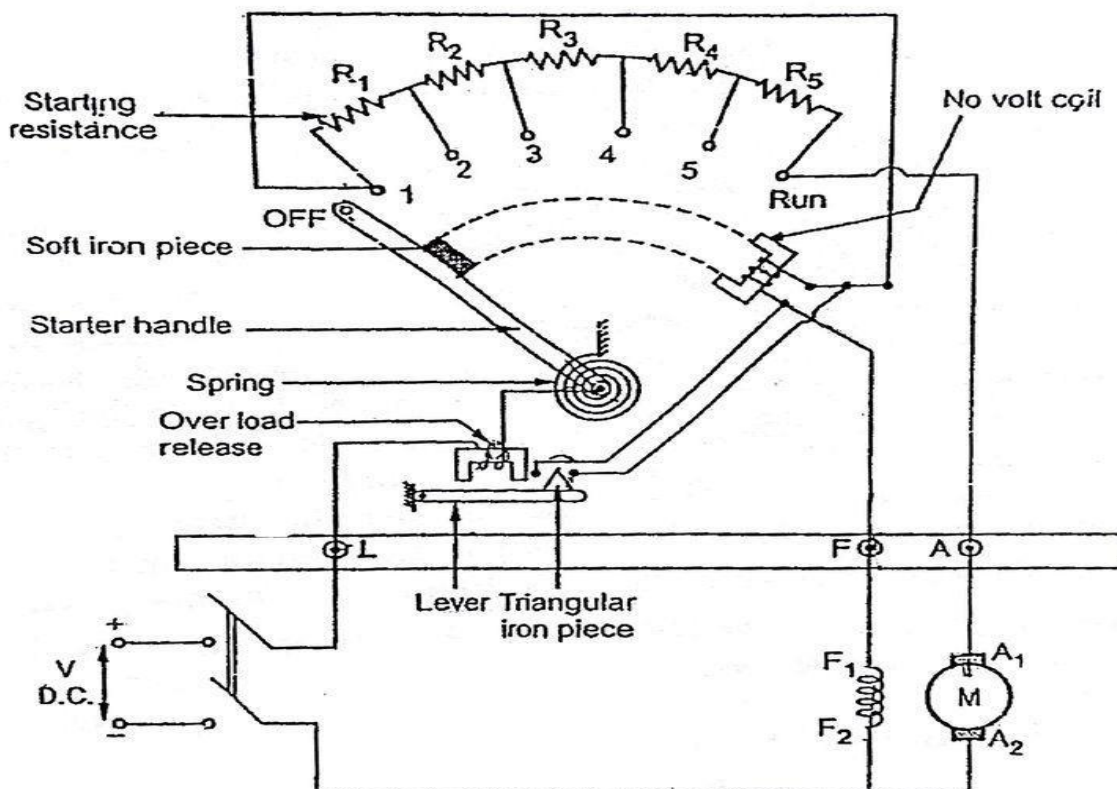

- Field winding will get supply via parallel path provided through stud 1 and NVC.
- Entire starting resistance is in series with the armature and limits the starting current.

As the handle moves further to stud 2,3,4,5 and finally RUN position. It bypasses the starting resistance and the motor rotates at normal speed.

NVC coil holds the starter in RUN position so it is also called as Hold on the coil.

Functions of No Volt Coil (NVC)

The field winding is supplied through NVC and field current makes it an electromagnet

- When the handle is at the RUN position, the soft iron piece on handle gets attracted by the magnetic force produced by NVC.

Whenever there is supply failure or field supply is broken then NVC loses its magnetism and unable to hold the handle. The spring action brings back the handle to OFF position.

NVC perform the similar action during low voltage condition and Save the device.

Functions of Overload release (OLR)

The motor current is supplied through OLR coil, which makes it an electromagnet

Below the OLR coil, there is an arm which is fixed at its fulcrum or lying horizontally

At the end of the arm, a small triangular iron piece is fitted which is in the proximity of two ends of the shorting cable of NVC.

It is so designed that, till the full load current OLR coil magnetism and gravitational force are balanced and OLR is unable to lift the lever.

Whenever motor draws high current the magnetism of the OLR coil pull the arm and triangular piece of the arm shorts both point of NVC coil.

NVC coil loses its magnetism and leaves the handle. the handle than retracts back to OFF position because of spring action. The motor will stop.

Drawbacks of Three-Point Starter

To increase the speed of the motor field resistance can be increased.

This will reduce the amount of current through shunt field.

As NVC is connected in series with shunt field, this small current will reduce the strength of the electromagnet

This holding magnet may release the arm of the handle during normal operation of the motor and disconnect it from the supply.

This can be overcome by Four-Point Starters,

A three-point starter is a device that *helps in starting and running the shunt wound motor or compound wound DC motor.*

Starters are used to protect DC motors from damage that can be caused by very high current and torque during startup. They do this by providing external resistance to the motor, which is connected in series to the motor's armature winding and restricts the current to an acceptable level.

OBSERVATIONS

SL NO	NO LOAD VOLTAGE	NO LOAD CURRENT
1		

RESULTS & CONCLUSIONS:

Reasoning questions:

1. Why starter is use to start a dc motor?
2. What is back emf?
3. What is value of back emf at the time of starting of motor?
4. When back emf of the dc motor is maximum?
5. What is the function of NVC?
6. What is the function of OLRC?
7. Why it is name three point starter?
8. In which type of Motor a three point starter is used?
9. What is the function of spring?
10. How adc motor is protected from a fault .

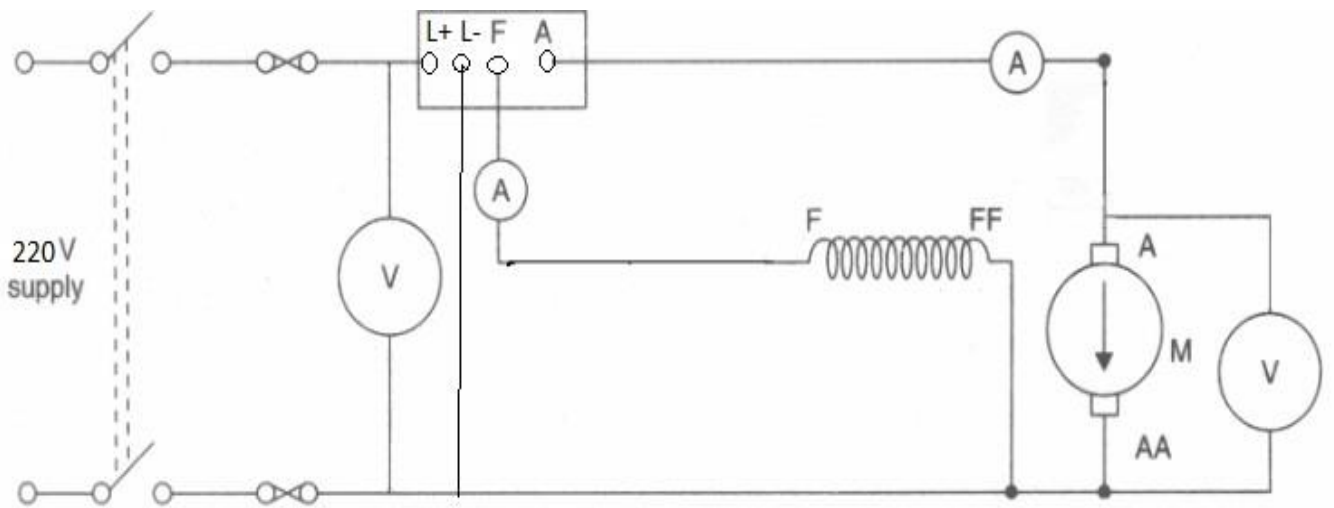

CIRCUIT DIAGRAM

6. STUDY OF FOUR POINT STARTER, CONNECT AND RUN A D.C COMPOUND MOTOR AND MESURE THE NO LOAD CURRENT

AIM: STUDY OF THREE POINT STARTER, CONNECT AND RUN A D.C SHUNT MOTOR AND MESURE THE NO LOAD CURRENT

APPARATUS REQUIRED:

S.NO	Name of the equipment	Range	Type	Quantity
1	DC Compound Motor	220 V, 2 HP, 1450 rpm, 3.8 Amp	Shunt	1 No
2	4 Point Starter	230 V, 5HP		1 No
3	Series Testing Board	230 v, 100 W	AC	1 No
4	Multimeter		Digital	1 No
5	Voltmeter	0-300 v	M.C. type	1 No
6	Ammeter	0-15 amp	M.C. type	1 No
7	Rheostats	400 Ohms, 5amp		1 No
8	Tachometer	10000 rpm	Digital	1 No
9	Insulated combination plier	0-300 mm	Insulated	1 No
10	Electrician Knife	0-50mm		1 No
11	Neon Tester	0-100 mm		1 No
12	Connecting Wire	1.5 sq. mm		5 m

THEORY

A three-point starter is a device that *helps in starting and running the shunt wound motor or compound wound DC motor.*

Starters are used to protect DC motors from damage that can be caused by very high current and torque during startup. They do this by providing external resistance to the motor, which is connected in series to the motor's armature winding and restricts the current to an acceptable level.

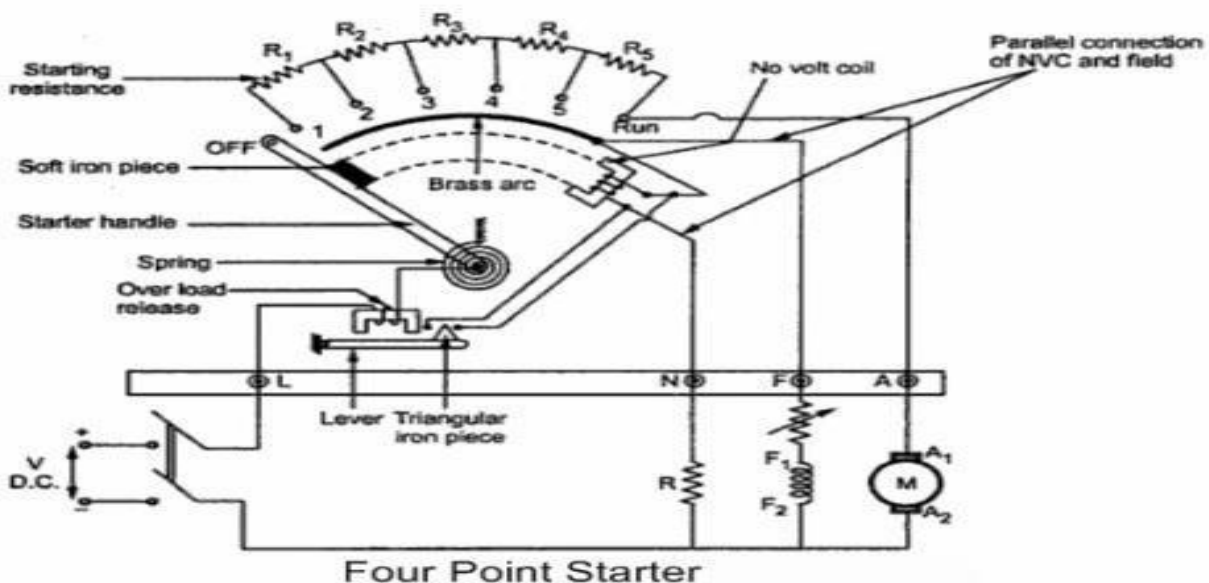

- 'L' Line terminal: (Connected to positive supply)
- 'A' Armature terminal. (Connected to armature winding)

- 'F' Field terminal (Connected to field winding)
- 'N' Neutral terminal(Connected to resistance)

Point L is further connected to electromagnet called OLR (overload release)

The second point of OLR is connected to the starter handle.

The handle is free to move on other side towards RUN against the force of spring A soft iron piece is attached to handle.

- A parallel path is derived from stud 1 to No Volt coil (NVC) and other end of NVC is connected to 'F' terminal.
- The Overload release (OLR) and No volt coil (NVC) are two protective devices.

Functions of No Volt Coil (NVC)

The field winding is supplied through NVC and field current makes it an electromagnet

- When the handle is at the RUN position, the soft iron piece on handle gets attracted by the magnetic force produced by NVC.

Whenever there is supply failure or field supply is broken then NVC loses its magnetism and unable to hold the handle. The spring action brings back the handle to OFF position.

NCV perform the similar action during low voltage condition and Save the device.

Functions of Overload release (OLR)

The motor current is supplied through OLR coil, which makes it an electromagnet

Below the OLR coil, there is an arm which is fixed at its fulcrum or lying horizontally

At the end of the arm, a small triangular iron piece is fitted which is in the proximity of two ends of the shorting cable of NVC.

It is so designed that, till the full load current OLR coil magnetism and gravitational force are balanced and OLR is unable to lift the lever.

Whenever motor draws high current the magnetism of the OLR coil pull the arm and triangular piece of the arm shorts both point of NVC coil.

NVC coil loses its magnetism and leaves the handle. the handle than retracts back to OFF position because of spring action. The motor will stop.

Operation

- Due to the movement of the handle over the studs, the handle gets in contact with the studs imposing the resistance into the circuit. This resistance slowing cuts down slowly as when the handle is moved on to the last stud.
- When the handle is at the first stud, the resistance is high. This way as it has high starting resistance it can oppose the huge current. This helps the motor to avoid high starting current when the resistance is high. As the handle is moved on to the studs further, the resistance gets decreased as it cuts the resistance.
- Due to the decrease in resistance, the current gets picked up slowly because resistance is decreased. Now, the handle moved is at the final position. Basically, there are two forces acting in

this operation, one is attraction force and the other is the opposing force. As and when the handle is moved, the handle attached to the notch attracts the electromagnet and the soft iron piece is attracted.

- The opposing force acting due to the spring helps in restraining the handle at its position. For the handle to be at the final position, the attracting force imparted should be greater than the opposing force. By any chance, if the opposing force is greater than the former then the handle returns to the initial position. To maintain proper speed and current limitations always make sure that the attraction force is greater.

RESULTS & CONCLUSIONS:

Reasoning questions:

1. Why starter is use to start a dc motor?
2. What is back emf?
3. What is value of back emf at the time of starting of motor?
4. When back emf of the dc motor is maximum ?
5. What is the function of NVC?
6. What is the function of OLRC?
7. Why it is name four point starter?
8. In which type of Motor a three point starter is used?
9. What is the function of spring?
10. How a dc motor is protected from a fault ?

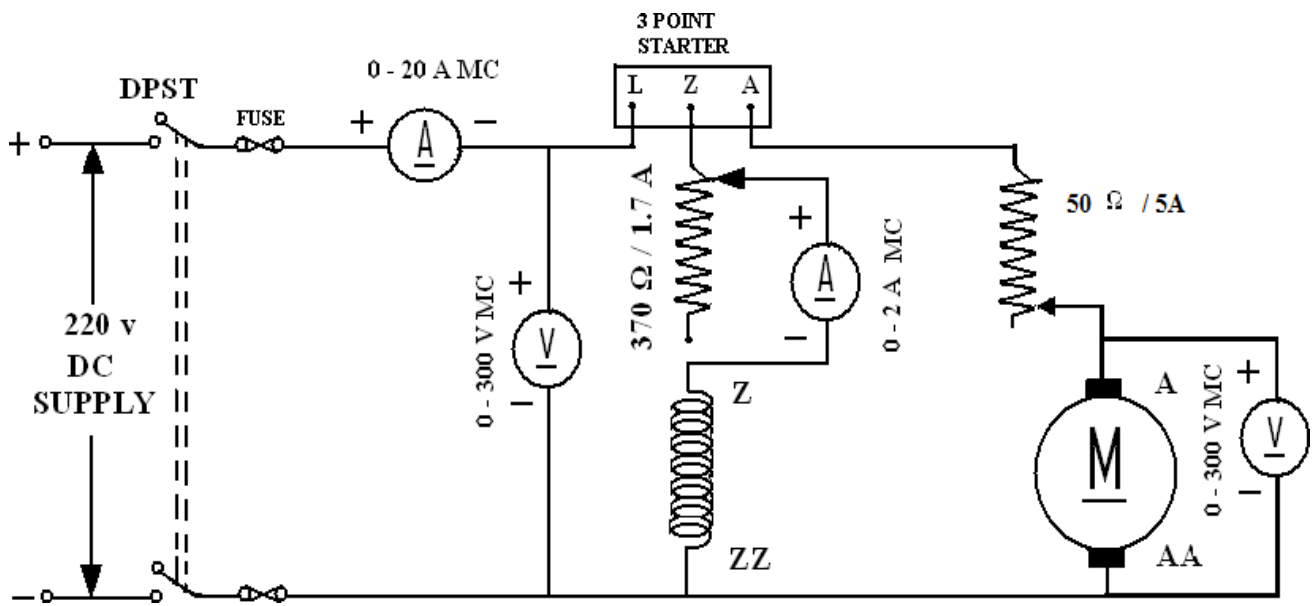

CIRCUIT DIAGRAM

further weakening flux adversely affects commutation.

Armature control method:

This method is used when speeds below the no-load speed are required.

As supply voltage is normally constant, the voltage across the armature is varied by inserting a variable rheostat (called controller resistance) in series with the armature circuit. As the controller resistance increased, potential difference across the armature is decreased, thereby decreasing the armature speed. For a load of constant torque, speed is approximately proportional to the potential difference across the armature. From the speed/ armature current characteristic it is seen that greater the resistance in the armature circuit, greater is the fall in speed.

The speed (N) with a total armature resistance R_t is related to the No-load speed N_0 by the following equation.

$$N = N_0 (1 - I_a R_t / V)$$

The load current following the speed will be zero is obtained by putting $N = 0$ in the above formula.

$$I_a = V / R_t$$

This is the maximum armature current and is known as stalling current.

OBSERVATION

1. Armature control method:-

S.NO	Armature current in Amps - I_a	Voltage across Armature V_a Volts	RPM (N)	Back emf $E_b = V - I_a R_a$ in volts

2. Field control method:-

S.NO	Shunt field Current- I_f in Amps	RPM - (N)

PROCEDURE:

1. Make the connections as shown in the figure.
2. Ensure maximum resistance in the armature circuit and minimum resistance in the field circuit.
3. Ensure free rotation of brake drum and switch ON the power supply.

Armature control method:

- a). Keep the field current constant and vary the armature resistance in steps.
- b). At each step, ensure field current is constant and note down the Armature voltage and speed till near rated speed.
- c). Finally adjust the armature resistance such that the voltage across the armature is 70-90v.

Field control method:

- a). Keep the armature voltage constant.
 - b). Take the speed and field resistance values varying the field resistance (decreasing I_f).
 - c). At each step, ensure the armature voltage is constant.
 - d). Repeat till near the rated speed.
4. Reset armature and field resistance to original values and switch OFF the machine.

GRAPHS:

1. Plot the graph between Speed Vs Armature Voltage
2. Plot the graph between Speed Vs Field current

RESULTS & CONCLUSIONS:

Reasoning Questions:

1. What will happen if the shunt field is open during running?
2. What is the purpose of NO VOLT coil in a D.C Motor?
3. How do you change the direct ion of rotation of DC shunt motor?
4. What are the methods of speed control in a DC shunt motor?
5. In which method of speed control, above the base speed can be achieved. Why?
6. List the merits and demerits of armature voltage control method?
7. What is the necessity of starter?
8. What is the function of OLR coil in Dc starters?
9. What is the advantage of 4-point starter over 3-point starter?
10. Which is the precise method of speed control of DC motors?

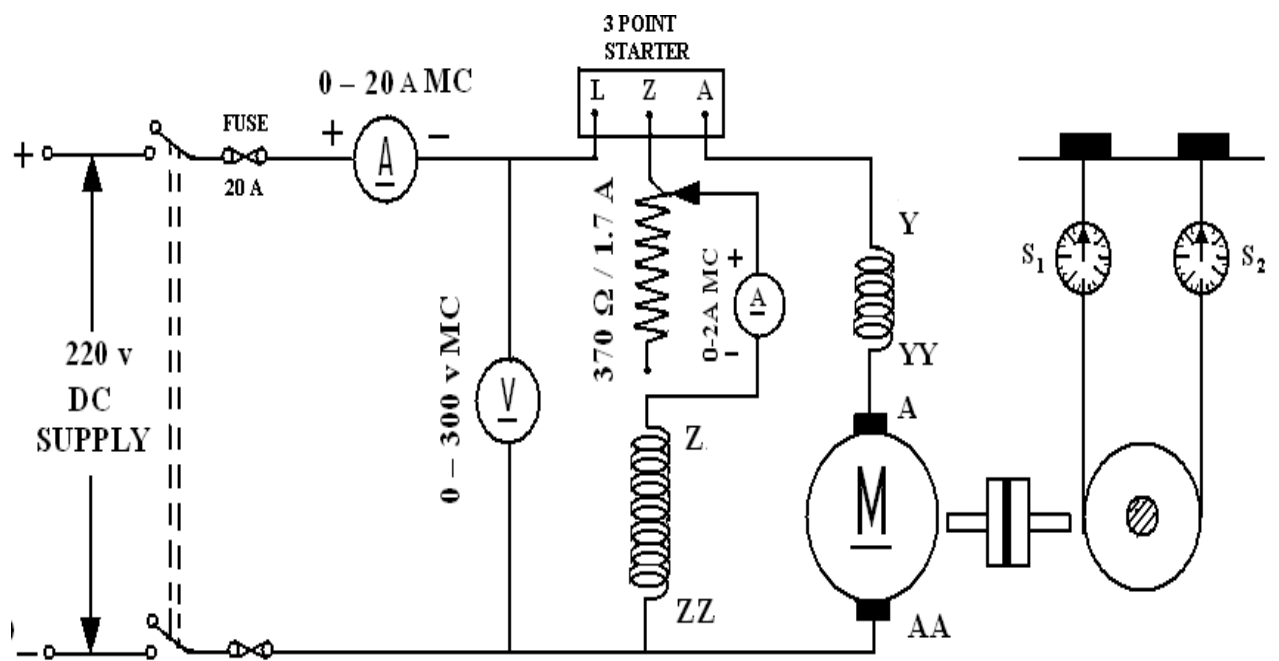

CIRCUIT DIAGRAM

8. DETERMINE THE ARMATURE CURRENT VS SPEED CHARACTERISTIC OF A DC SHUNT MOTOR

AIM-DETERMINE THE ARMATURE CURRENT VS SPEED CHARACTERISTIC OF A DC SHUNT MOTOR

APPARATUS REQUIRED

S.NO	Name of the equipment	Range	Type	Quantity
1	DC Shunt Motor	220 V, 2 HP, 1450 rpm, 3.8 Amp	Shunt	1 No
2	4 Point Starter	230 V, 5HP		1 No
3	Series Testing Board	230 v, 100W	AC	1 No
4	Multimeter		Digital	1 No
5	Voltmeter	0-300 v	M.C. type	2 No
6	Ammeter	0-15 A	M.C.type	1 No
7	Rheostats	400 Ohms, 5amp		2 Nos
8	Tachometer	10000 rpm	Digital	1 No
9	Insulated combination plier	0-300 mm		1 No
10	Electrician Knife	0-50mm		1 No
11	Neon Tester	0-100 mm		1 No
12	Connecting Wire	1.5 sq. mm		5 m

THEORY:

The performance of a DC motor can be judged by its characteristics and a motor for any particular application can be selected easily. In this article, dc motor characteristics are discussed in detail.

The performance characteristics of DC motor are

- Torque versus armature current (T v/s I_a)
- Speed versus armature current (N v/s I_a)
- Torque versus speed (T v/s N)

Speed Current Characteristic (N v/s I_a)

Back EMF of shunt motor is given by

$$E_b = V - I_a R_a = (P\phi NZ)/60A$$

Because P, N, Z and A are constant

Therefore, $E_b \propto N\phi$

$$\text{or } V - I_a R_a \propto N\phi$$

$$\text{or } N \propto (V - I_a R_a) / \phi \dots\dots(1)$$

the field flux of shunt motor is almost constant. Therefore, the numerator of RHS of equation (1) decreases with increase in load (or I_a).

So there is a little fall in speed with the increase in load, hence the curve bends slightly as the load is increased due to increased $I_a R_a$ voltage drop.

GRAPH

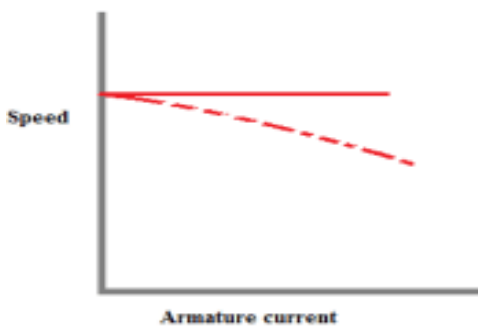

PROCEDURE :

- 1) Connect the circuit diagram as shown in Fig.
- 2) Switch ON the power supply and start the motor with help of 3 point starter.
- 3) Gradually increase the load (mechanical or break load) step by step.
- 4) Note down the voltage, current, tension F_1 and F_2 , speed N for every step.
- 5) Disconnect the motor from power supply.
- 6) Draw the three characteristics of dc shunt motor.

OBSERVATION TABLE :

Sl No	Voltage ,V (volt)	Current I (amp)	Force (Kgf)			Speed N (rpm)
			F_1	F_2	$F = F_1 - F_2$	
1						
2						
3						
4						
5						

Diameter of pulley, $d =$ _____ m.

RESULT: Draw the torque-current, speed-current and speed torque characteristic of d.c. shunt motor.

DISCUSSION :

1. How armature reaction affect the three characteristics of dc shunt motor?
2. Explain the nature of efficiency vs. load curve?
3. If the supply voltage is dropped by half, what is the effect on three characteristics?
4. What happen if suddenly load is removed from the motor?

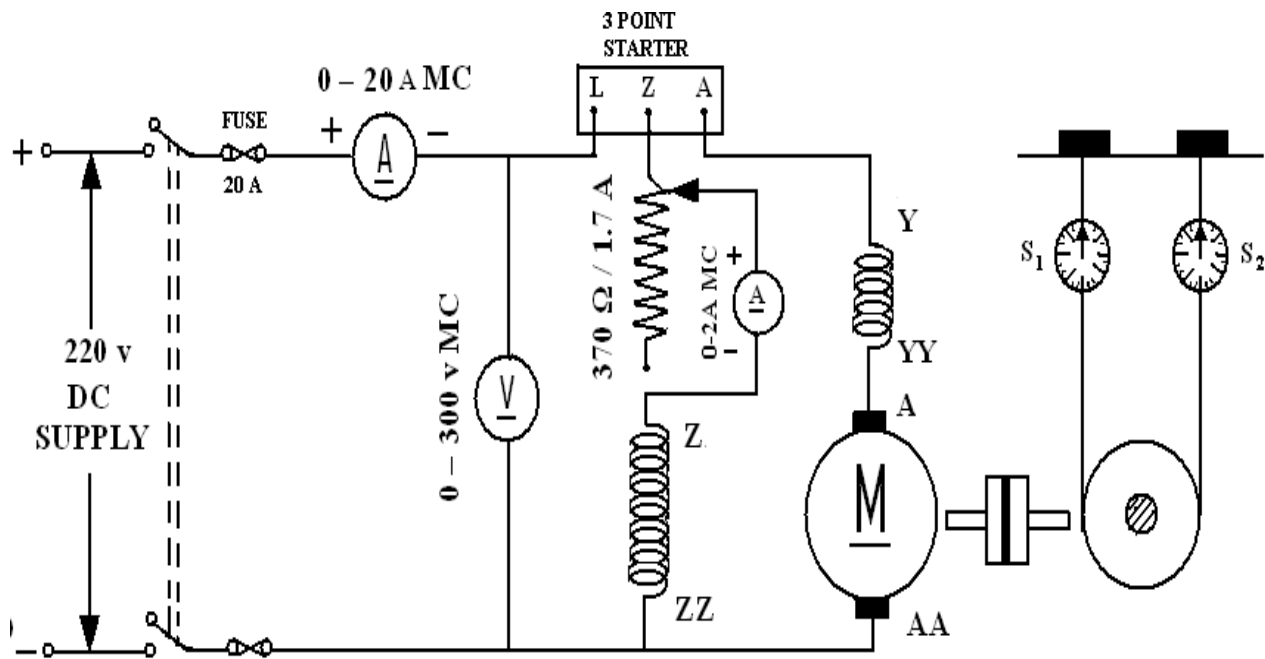

CIRCUIT DIAGRAM

$$\text{Torque}(T) = (S_1 - S_2) R \times 9.81 \text{ N-m.}$$

$$\text{Motor output} = \frac{2\pi NT}{60} \text{ watt}$$

$$\text{Motor input} = VI \text{ watts}$$

$$\text{Efficiency} = \frac{\text{output}}{\text{input}} = \frac{2\pi NT}{60 (VI)}$$

Measure the radius of the pulley=

OBSERVATIONS:

Radius of the pulley (in meters) =

S.NO	VL	IL	If	Ia	N	S1	S2	T	O/P	I/P	%η

Model Graph:

PROCEDURE:

1. Make the connections as per the circuit diagram.
2. Ensure minimum resistance in the field circuit and check the brake drum for free rotation.
3. Switch on the supply and slowly push the starter till the end.
4. Adjust the speed of the motor to the rated value by adjusting field

resistance.

5. Take the No-load readings of voltmeter, Ammeter and speed.
6. Slowly increase the load on the brake pulley by tightening the wheels in steps. At each step note down the readings of voltmeter, Ammeter, spring balance readings and speed.
7. Release the load on the pulley and switch OFF the supply.

PRECAUTIONS:

- 1). Avoid hanging wires and loose connections.
- 2). Make sure that the initial value of Field Resistance is minimum.
- 3). Ensure that the loading belt is slack when the machine is started.

GRAPHS:

Plot the graphs: -

- | | |
|-------------------------|---------------------------|
| 1. Efficiency Vs Output | 2. Speed Vs Output |
| 3. Torque Vs Output | 4. Load current Vs Output |
| 5. Speed Vs Torque. | |

RESULTS & CONCLUSIONS:

Reasoning questions:

1. What is the back emf of the motor?
2. Why the speed falls as load increases for a DC shunt motor?
3. What are the applications of Dc shunt motor?
4. When is the efficiency of the motor is maximum?
5. Define commutation?
6. What should be the position of rheostat in the field circuit while starting?
7. What is the nature of load connected across DC motor?
8. What will happen when Dc shunt motor is started with load?
9. Give the expressions for various torques in DC motors?
10. What is the effect on speed if part of the field winding is shorted?

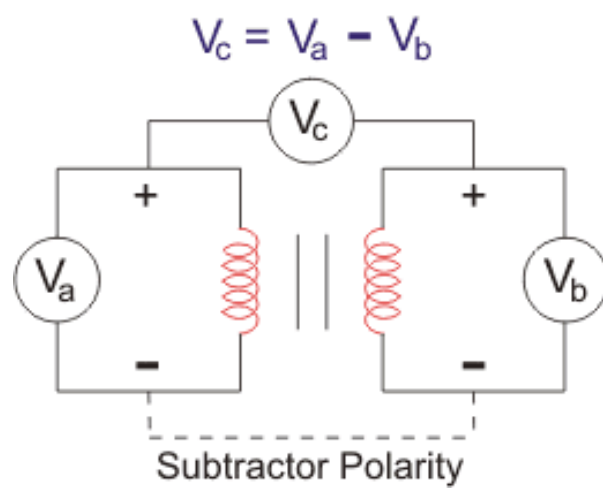
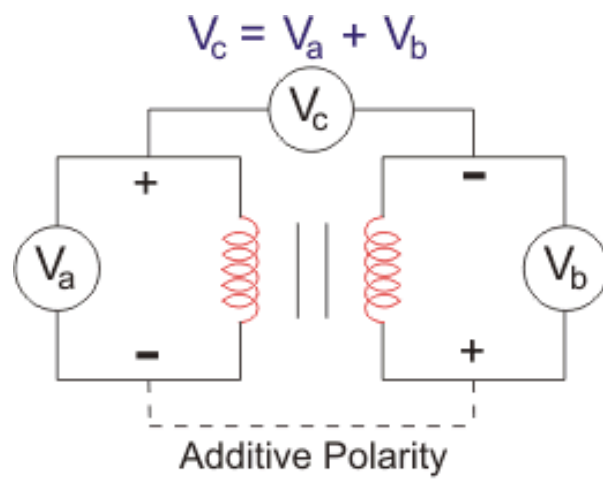

10.IDENTIFICATION OF TERMINALS,DETERMINATION OF VOLTAGE TRANSFORMATION RATIO OF A SINGLE PHASE TRANSFORMER

AIM: IDENTIFICATION OF TERMINALS, DETERMINATION OF VOLTAGE TRANSFORMATION RATIO OF A SINGLE PHASE TRANSFORMER

APPARATUS REQUIRED:

S.No.	Name of the equipment	Range	Type	Quantity
1	Transformer	1 Ph, 230 V ,50 Hz,4.35 Amp	Oil core	1No
2	Ammeter	(0-10)A (0-5) A	MI type	1No 1No
3	Voltmeter	(0-150)V (0-300) V	MI type	1 No 1 No
4	Wattmeter	(300V, 5A) (150V, 5A)	UPF	1 No 1 No
5	Auto Transformer	1 Φ , (0-260)V,2.7 KVA	-	1NO
6	Resistive Load	5KW, 230V	-	1NO
7	Connecting Wires	2.5sq.mm	Multi core	5 m
8	Insulated Combination Plier	0-300 mm		1 NO
9	Neon Tester	0-100 mm		1 NO

THEORY

POLARITY TEST

Current flows from high voltage point to low voltage point due to the potential difference between them. Here, electrical polarity comes into the picture. Electrical polarity simply describes the direction of the current flow. When we look into DC system, we find that one pole is always positive and the other one is always negative that imply that the current flows in one direction only. But when we look into an AC system, the terminals are changing their polarity periodically, and the direction of the current also changes accordingly.

We use dot convention to identify the voltage polarity of the mutual inductance of two windings. The two used conventions are:

1. If a current enters the dotted terminal of one winding, then the voltage induced on the other winding will be positive at the dotted terminal of the second winding.
2. If a current leaves the dotted terminal of one winding, then the polarity of the voltage induced in the other winding will be negative at the dotted terminal of the second winding.

We can categorise the polarity of the transformer to two types,

1. Additive Polarity
2. Subtractive Polarity

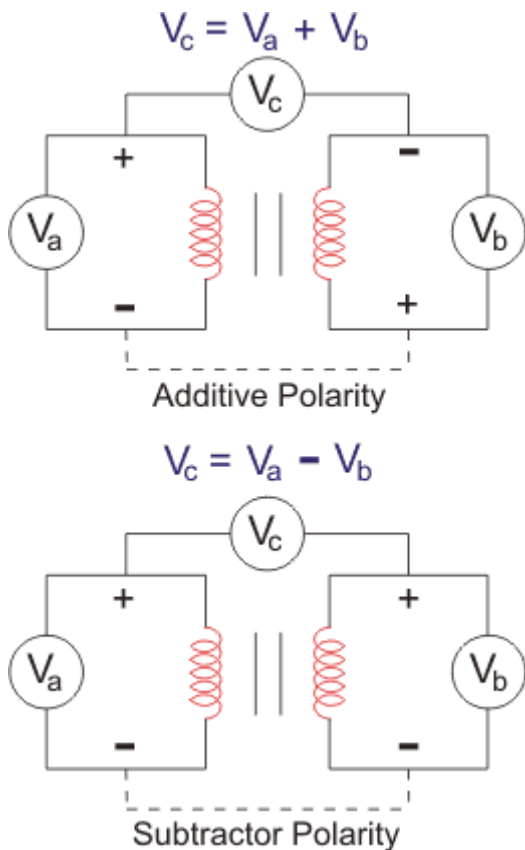

Additive Polarity

In additive polarity, the voltage (V_c) between the primary side (V_a) and the secondary side (V_b) will be the sum of both high voltage and the low voltage, i.e. we will get $V_c = V_a + V_b$

Subtractive Polarity

In subtractive polarity, the voltage (V_c) between the primary side (V_a) and the secondary side (V_b) will be the difference of both high voltage and the low voltage, i.e. we will get $V_c = V_a - V_b$

In subtractive polarity, if $V_c = V_a - V_b$, it is a step-down transformer and if $V_c = V_b - V_a$, it is a step-up transformer.

RATIO TEST

The transformer turns ratio test is used to determine the number of turns in one winding of a transformer in relation to the number of turns in the other windings of the same phase of the transformer.

The transformer polarity test determines the vectoral relationships of the various transformer windings. The transformer ratio test is used as both an acceptance test and a maintenance test, while the polarity test is primarily an acceptance test.

$$\text{Theoretical turn ratio} = \frac{\text{HV winding voltage}}{\text{LV winding voltage}}$$

PROCEDURE: -

POLARITY TEST

1. Make the connections as per circuit dia.
2. Switch on the supply
3. Take the reading of voltages V_1 , v_2 , V_3 . In case of $V_2 < V_1$ the polarity is subtractive.
4. Repeat the step 3 after connecting A_1 and a_2 in case $V_3 > V_1$ the polarity is additive.
5. Switch off the A.C. supply.

RATIO TEST:

1. First, the tap changer of transformer is kept in the lowest position and LV terminals are kept open.
2. Then apply 1-phase 230 V supply on HV terminals. Measure the voltages applied on HV and induced voltages at LV terminals simultaneously,
3. After measuring the voltages at HV and LV terminals, the tap changer of transformer should be raised by one position and repeat test.
4. Repeat the same for each of the tap position separately. Calculate the turns ratio by using formula.

OBSERVATIONS:

SR.NO	HV SIDE VOLTAGE	LV SIDE VOLTAGE	TRUNS RATIO
1			
2			
3			
4			
5			

CALCULATION

Turns ratio of given transformer is_____.

RESONING QUESTION:

- 1- what is the need of polarity test?
- 2- what is turn ratio?
- 3- What do you mean by additive polarity?
- 4- What do you mean by subtractive polarity?
- 5- What is an ideal transformer?
- 6- What is a practical transformer?
- 7- Which value of voltage and current are used for calculation of transformation ratio?
- 8- What is the value of transformation ratio of a Ideal transformer?

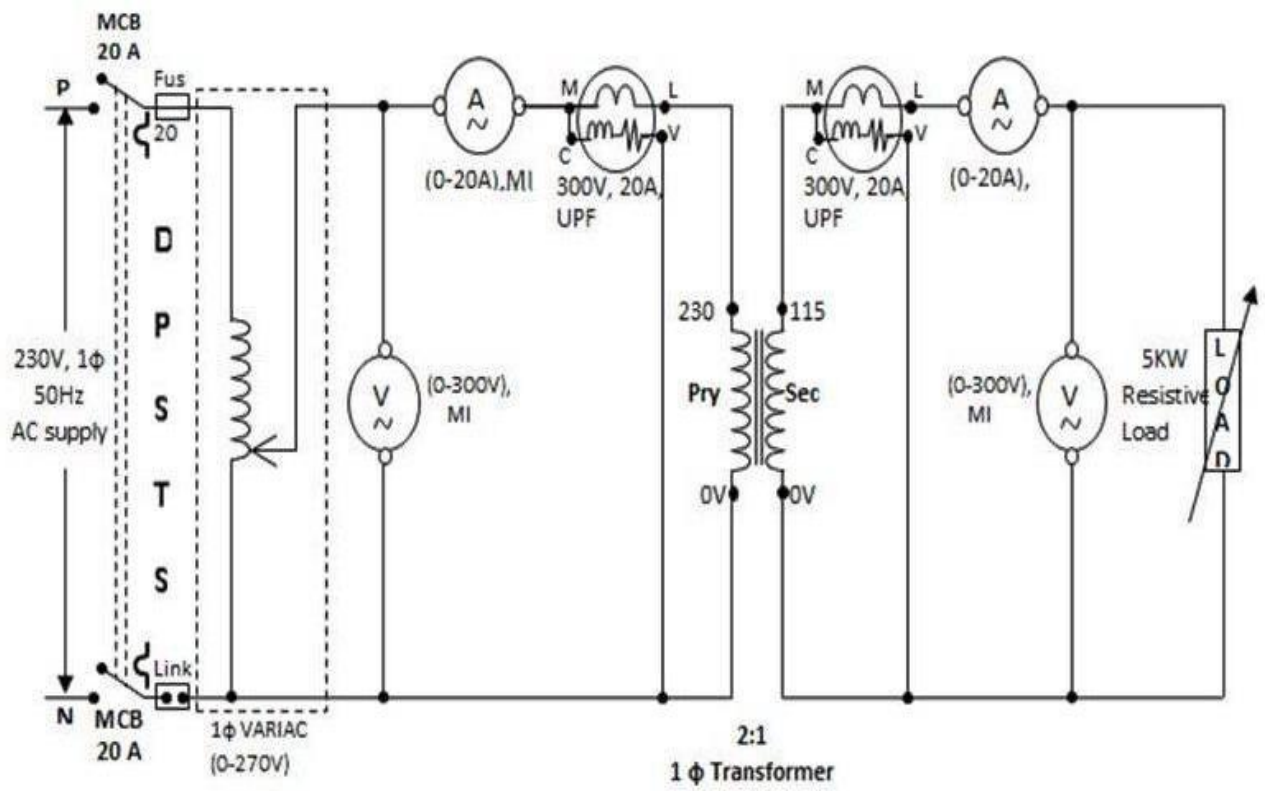

CIRCUIT DIAGRAM

12.DETERMINE THE REGULATION OF SINGLE PHASE TRANSFORMER AT DIFFERENT LOADS

AIM: TO FIND THE REGULATION OF SINGLE PHASE TRANSFORMER BY USING LOAD TEST.

APPARATUS REQUIRED:

S.No.	Name of the equipment	Range	Type	Quantity
1	Transformer	1 Ph, 230 V ,50 Hz, 4.35 Amp	Oil core	1No
2	Ammeter	(0-10)A (0-5) A	MI type	1No 1No
3	Voltmeter	(0-150)V (0-300) V	MI type	1 No 1 No
4	Wattmeter	(300V, 5A) (150V, 5A)	UPF	1 No 1 No
5	Auto Transformer	1 Φ , (0-260)V	-	1NO
6	Resistive Load	5KW, 230V	-	1NO
7	Connecting Wires	2.5sq.mm	Multi core	5 m
8	Insulated Combination Plier	0-300 mm		1 NO
9	Neon Tester	0-100 mm		1 NO

THEORY

VOLTAGE REGULATION OF A TRANSFORMER

The voltage regulation is defined as the change in the magnitude of receiving and sending the voltage of the transformer. The voltage regulation determines the ability of the transformer to provide the constant voltage for variable loads.

When the transformer is loaded with continuous supply voltage, the terminal voltage of the transformer varies. The variation of voltage depends on the load and its power factor.

Mathematically, the voltage regulation is represented as

$$\text{Voltage Regulation} = \frac{E_2 - V_2}{E_2}$$

$$\% \text{ Voltage Regulation} = \frac{E_2 - V_2}{E_2} \times 100$$

where,

E_2 - secondary terminal voltage at no load

V_2 - secondary terminal voltage at full load

The voltage regulation by considering the primary terminal voltage of the transformer is expressed as,

$$\% \text{ Voltage Regulation} = \frac{V_1 - E_1}{V_1} \times 100$$

Let us understand the voltage regulation by taking an example explained below

If the secondary terminals of the transformer are open circuited or no load is connected to the secondary terminals, the no-load current flows through it. If the no current flows through the secondary terminals of the transformer, the voltage drops across their resistive and reactive load become zero. The voltage drop across the primary side of the transformer is negligible.

If the transformer is fully loaded, i.e., the load is connected to their secondary terminal, the voltage drops appear across it. The value of the voltage regulation should always be less for the better performance of transformer.

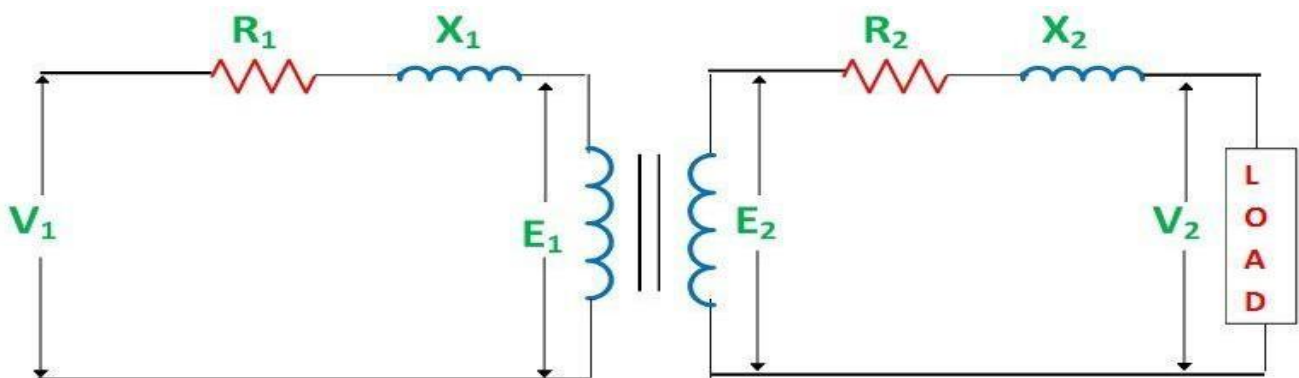

Circuit Globe

From the circuit diagram shown above, the following conclusions are made

The primary voltage of the transformer is always greater than the emf induces on the primary side. $V_1 > E_1$

The secondary terminal voltage at no load is always greater than the voltage at full load condition. $E_2 > V_2$

By considering the above circuit diagram, the following equations are drawn

$$V_1 = I_1 R_1 \cos\phi_1 + I_1 X_1 \sin\phi_1 + E_1$$

$$E_2 = I_2 R_2 \cos\phi_2 + I_2 X_2 \sin\phi_2 + V_2$$

The approximate expression for the no-load secondary voltage for the different types of load is

For inductive load

$$E_2 = I_2 R_{02} \cos\phi_2 + I_2 X_{02} \sin\phi_2 + V_2$$

OR

$$E_2 - V_2 = I_2 R_{02} \cos\phi_2 + I_2 X_{02} \sin\phi_2$$

OR

$$\frac{E_2 - V_2}{E_2} \times 100 = \frac{I_2 R_{02}}{E_2} \times 100 \cos\phi_2 + \frac{I_2 X_{02}}{E_2} \times 100 \sin\phi_2$$

Where,

$\frac{I_2 R_{02}}{E_2} \times 100$ is a percentage resistance drop

$\frac{I_2 X_{02}}{E_2} \times 100$ is a percentage reactance drop

For Capacitive load

$$E_2 = I_2 R_{02} \cos\phi_2 - I_2 X_{02} \sin\phi_2 + V_2$$

OR

$$E_2 - V_2 = I_2 R_{02} \cos\phi_2 - I_2 X_{02} \sin\phi_2$$

OR

$$\frac{E_2 - V_2}{E_2} \times 100 = \frac{I_2 R_{02}}{E_2} \times 100 \cos\phi_2 - \frac{I_2 X_{02}}{E_2} \times 100 \sin\phi_2$$

PROCEDURE:

1. Connections are made as per the circuit diagram.
2. After checking the no load condition, minimum position of auto transformer and DPST switch is closed.
3. Ammeter, Voltmeter and Wattmeter readings on both primary side and secondary side are noted.
4. The load is increased and for each load, Voltmeter, Ammeter and Wattmeter readings on both primary and secondary sides are noted.
5. Again no load condition is obtained and DPST switch is opened.

OBSERVATION:

SI.NO	NOLOAD VOLTAGE	FULL LOAD VOLTAGE	SECONDARY CURRENT	TYPE OF LOAD	PERCENTAGE REGULATION
1					
2					
3					
4					
5					

RESULT:

Thus we have been obtained the characteristic curve of 1Φ transformer.

PRECAUTIONS:

1. Auto Transformer should be in minimum position.
2. The AC supply is given and removed from the transformer under no load condition.

Reasoning questions:

1. List the application of Transformer and types.
2. What do you understand by regulation of a transformer?
3. What are the other methods of testing transformers?
4. What is the disadvantage of testing a transformer using load test?
5. What are the reasons for the drop in terminal voltage as the secondary current is increased

13. POLARITY TEST OF SINGLE PHASE TRANSFORMER AND PARALLEL OPERATION OF TWO 1-Φ TRANSFORMERS.

AIM: POLARITY TEST OF SINGLE PHASE TRANSFORMER AND PARALLEL OPERATION OF TWO 1-Φ TRANSFORMERS.

APPARATUS REQUIRED:

S.No.	Name of the equipment	Range	Type	Quantity
1	Transformer	1 Ph, 230 V ,50Hz,4.35 Amp	Oil core	2 NOS
3	Voltmeter	(0-150)V (0-300) V	MI TYPE MI TYPE	1 NO 1 NO
4	Resistive Load	5KW, 230V	Resistive-	1NO
5	Connecting Wires	2.5sq.mm	Copper	5 m
6	Insulated Combination Plier	0-300 mm		1 NO
7	Neon Tester	0-100 mm		1NO
5	Auto Transformer	1Φ, (0-260)V	-	1NO

THEORY

1. POLARITY TEST :

Polarity testing of transformer is vital before connecting them in parallel. Otherwise, with incorrect polarity, it is not possible to connect them in parallel. The two terminals of primary are marked as A_1 and A_2 and other two terminals of secondary are marked as a_1 and a_2 respectively as shown in fig. To determine the relative polarity of two-winding transformer, the two winding are connected in series across a voltmeter, while one of the winding is excited from a suitable voltage source as shown in fig. If the polarities of the windings are as marked on the diagram, voltmeter should read $V = V_1 \sim V_2$ and if it reads $(V_1 + V_2)$ the polarity marking of one of the winding must be interchanged.

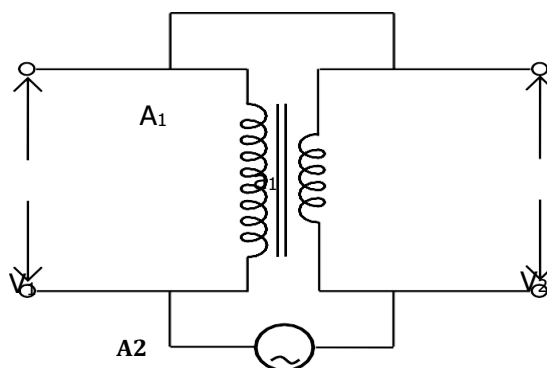

2 .Parallel Operation

The Transformer is said to be in **Parallel Operation** when their primary windings are connected to a common voltage supply, and the secondary windings are connected to a common load

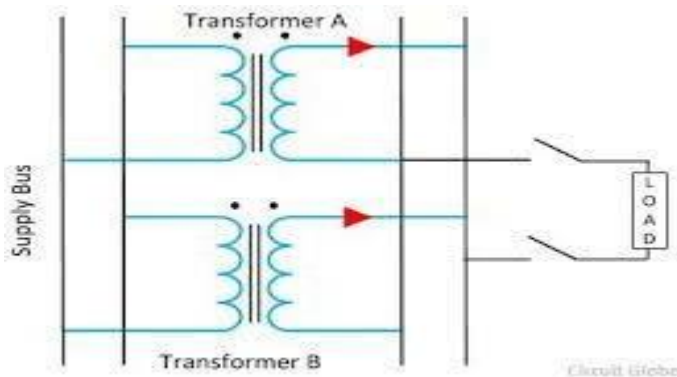

Need of parallel operation of Transformers

1. To maximize electrical power system efficiency:
Generally electrical power transformer gives the maximum efficiency at full load. If we run numbers of transformers in parallel, we can switch on only those transformers which will give the total demand by running nearer to its full load rating for that time. When load increases, we can switch by one other transformer connected in parallel to fulfill the total demand. In this way we can run the system with maximum efficiency.
2. To maximize electrical power system availability:
If numbers of transformers run in parallel, we can shutdown any one of them for maintenance purpose. Other parallel transformers in system will serve the load without total interruption of power.
3. To maximize power system reliability:
If any one of the transformers run in parallel, is tripped due to fault of other parallel transformers is the system will share the load, hence power supply may not be interrupted if the shared loads do not make other transformers over loaded.
4. To maximize electrical power system flexibility:
There is always a chance of increasing or decreasing future demand of power system. If it is predicted that power demand will be increased in future, there must be a provision of connecting transformers in system in parallel to fulfill the extra demand because, it is not economical from business point of view to install a bigger rated single transformer by forecasting the increased future demand as it is unnecessary investment of money. Again if future demand is decreased, transformers running in parallel can be removed from system to balance the capital investment and its return.

Conditions for Parallel Operation of Transformers

When two or more transformers run in parallel, they must satisfy the following conditions for satisfactory performance. These are the conditions for parallel operation of transformers.

1. Same voltage ratio of transformer.
2. Same percentage impedance.
3. Same polarity.
4. Same phase sequence.

PROCEDURE:

1. POLARITY TEST

- 1) Connect the circuit as shown in Fig.
Excite the primary from single phase AC supply
- 1) Take the Voltmeter reading V_1 , V_2 and V_3 .

- 2) Marked the polarity on the basis of the voltmeter reading.
Disconnect the supply and this test is performed on other two transformers

2. PARELLEL OPERATION

1. Circuit connections are made as shown in the circuit diagram .
2. Keeping the load switch (S_2) and SPST switch (S_3) in open position, the supply switch (S_1) is closed.
3. By varying the 1- Φ auto transformer the rated voltage of the transformers is applied. [Say 230V].
4. The reading of the voltmeter connected across SPST switch (S_3) is observed. It should read zero; if not, (if shows double the supply voltage) the auto transformer is brought back to its zero output position then the supply switch (S_1) is opened.
5. The secondary connections of any one of the transformers is interchanged and close the supply switch (S_1).
6. Now close the SPST switch (S_3). (Ensuring voltmeter V_2 reads zero voltage)
7. The load switch (S_2) is Closed. Gradually the load is applied in steps. At each step all the meter readings are noted down. The load is applied until the full load current of both the transformers reached.
8. Gradually the load is removed, the SPST switch (S_3) and load switch (S_2) are opened.
9. Gradually reduce the auto transformer voltage to zero then supply switch (S_1) is opened

OBSERVATION TABLE :

1. POLARITY TEST

TABLE - I

Terminal Sorted	Voltmeter V_1(volt)	Voltmeter V_2(volt)	Voltmeter V_3(volt)	Polarity

2. COMMON LOAD SHARING BETWEEN TWO PARALLEL TRANSFORMER

TABLE-2

Sl. No	W ₁ (Watt)	W ₂ (Watt)	W ₃ (Watt)	I ₁ (Amps)		I ₂ (Amps)		I ₃ (Amps)
				Actual	Theoretical	Actual	Theoretical	

Reasoning questions

- 1-what is the necessary of parallel operation?
- 2 -what are the conditions for parallel operation?
- 3-what happened if two different frequency transformers are connected in parallel?
- 4-Is rating of transformer is necessary for parallel operation?
- 5-what are the advantages of parallel operation?

